

SVEA GC-Stolpe

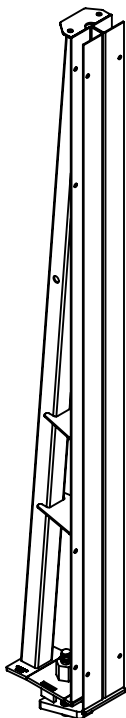

16, 18 & 30 mm

Varmförzinkad



Stål



10

[mm]

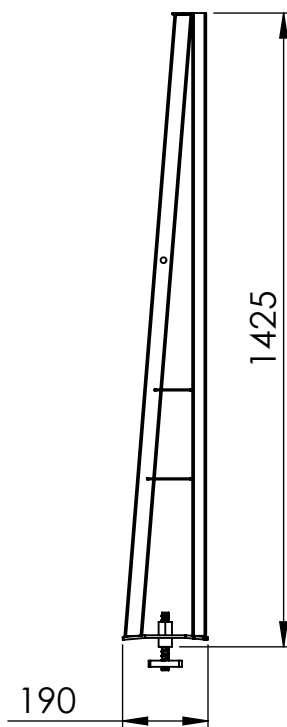
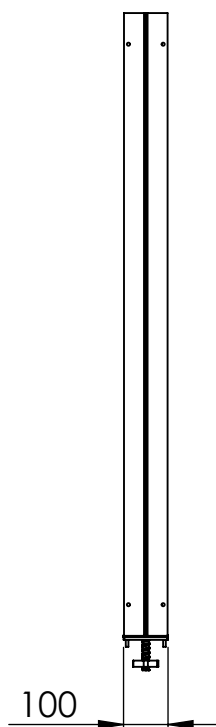

Tillbehör

833191 - GC-räcke 2.1 m

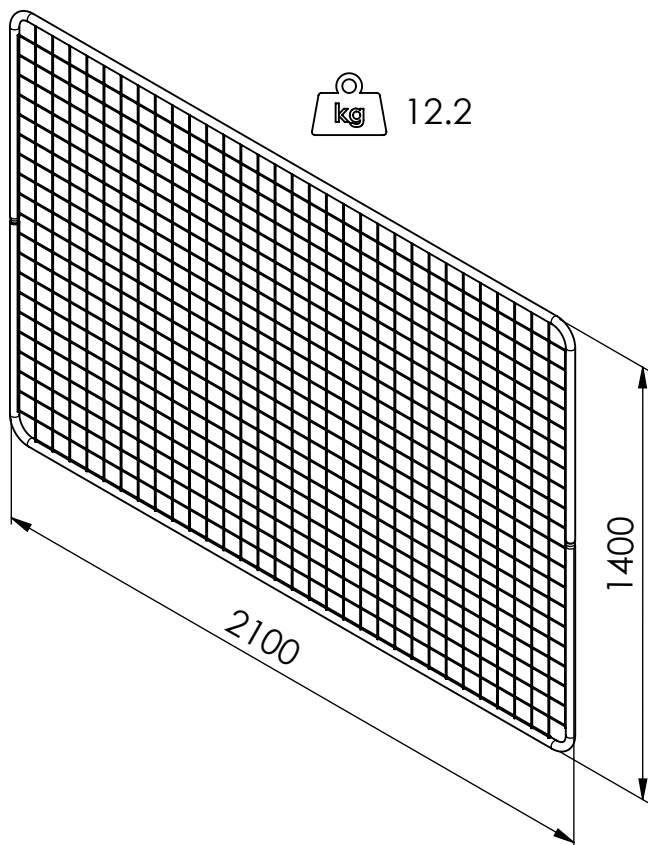

833075 - GC-räcke 1.4 m

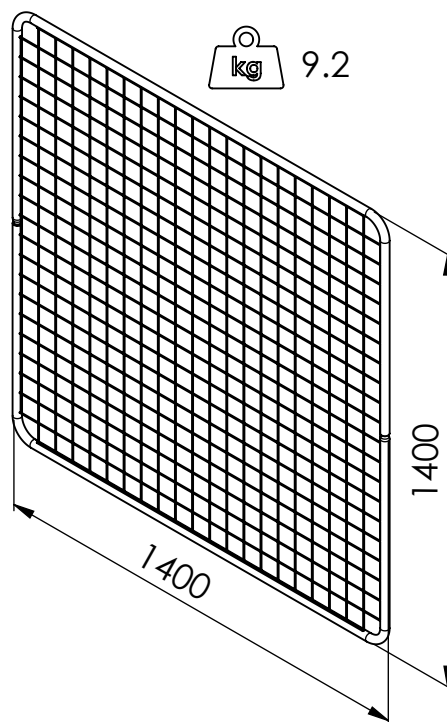

300602 - GC Gångjärn

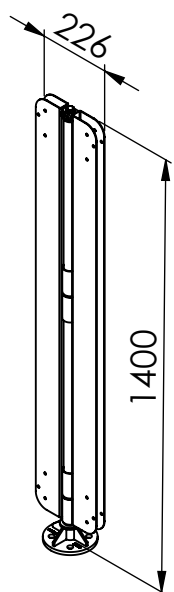

300611 - Lås Sprint

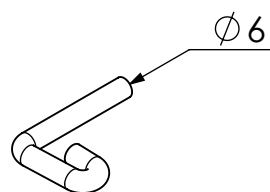

[mm]

8341960 - Överlappskoppling

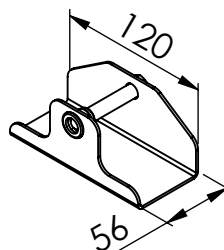

Montage

1.

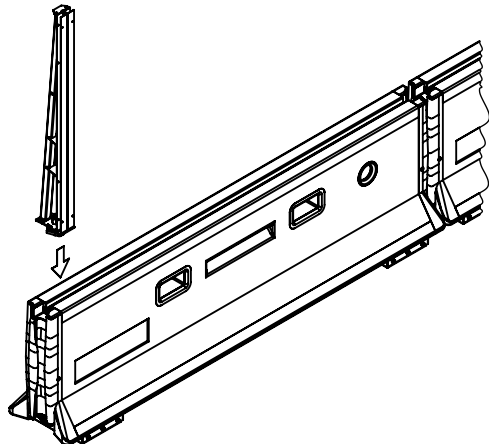

2.

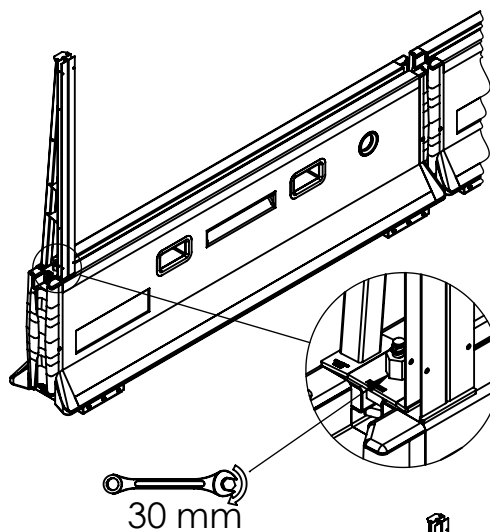

3.

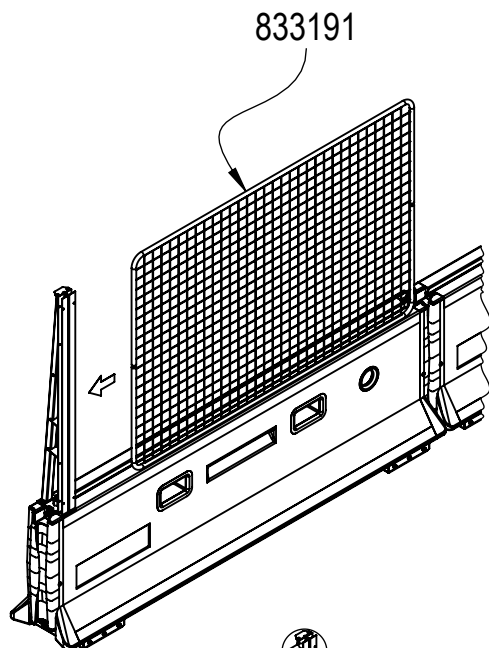

4.

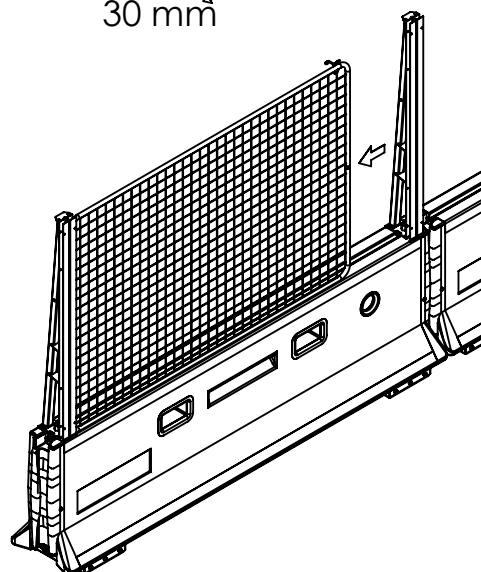

5.

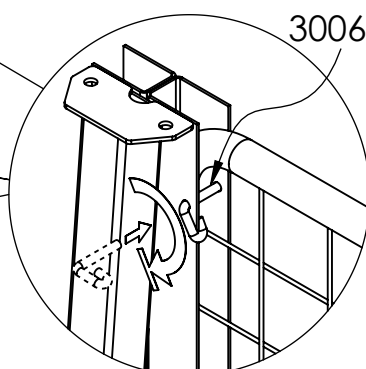
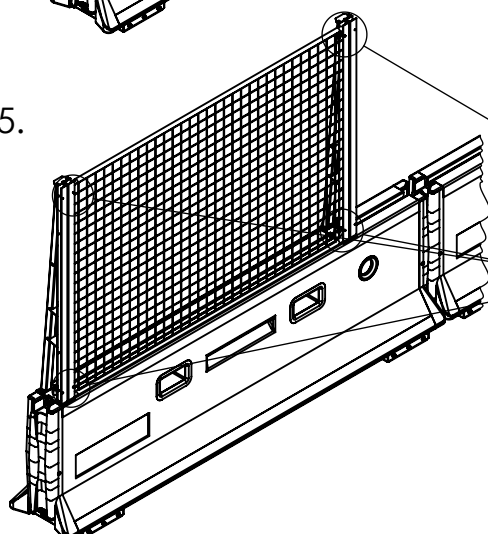

300611 Alternativt M6 skruv och mutter.

x4 =



Montage

Undvik att placera en stolpe i skarven mellan två barriärer. Använd istället ett kort nät till att förkjuta stolpen.

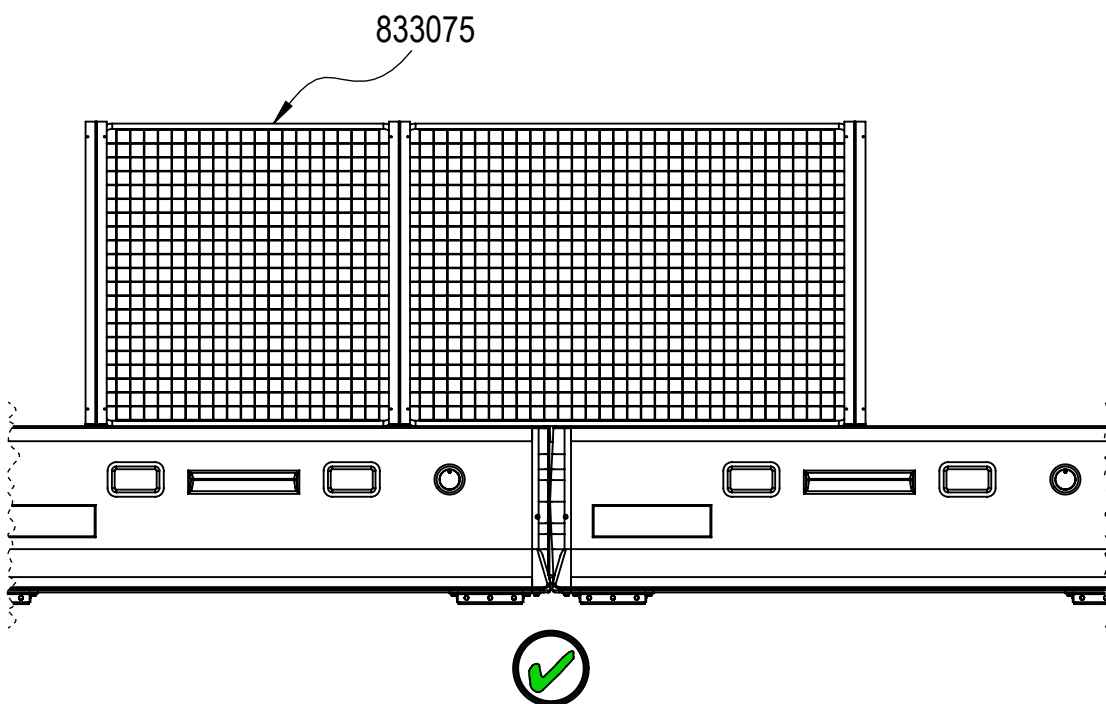
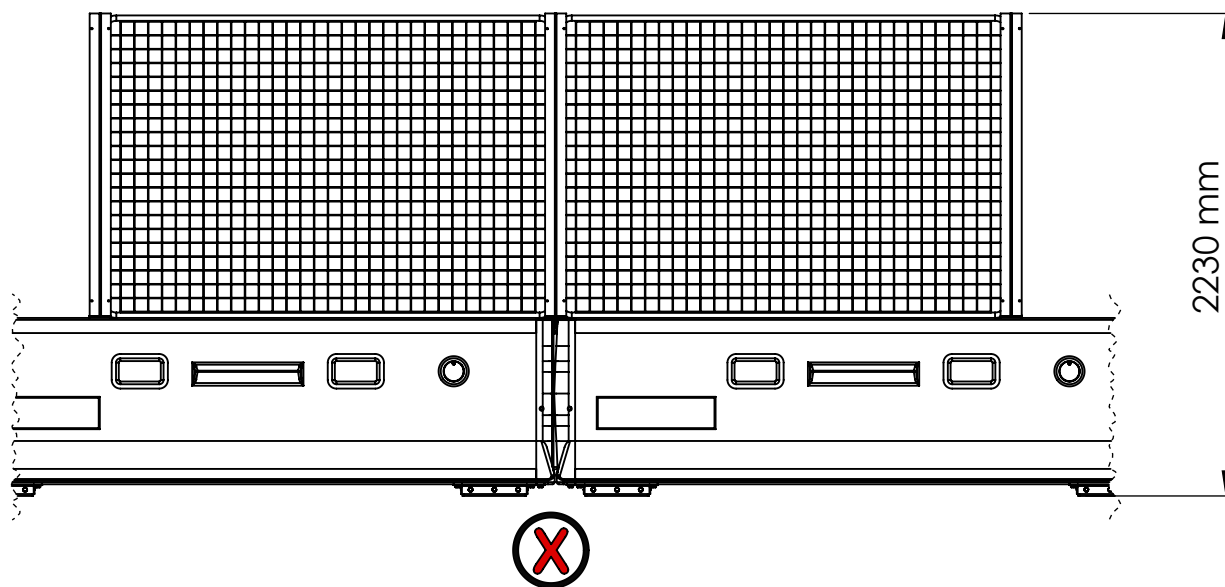

Montage

Hörnmontage

Om möjligt, utgå alltid i från ett hörn.
Vid fast avstånd från hörn till sista stolpen fortsätt till nästa sida.

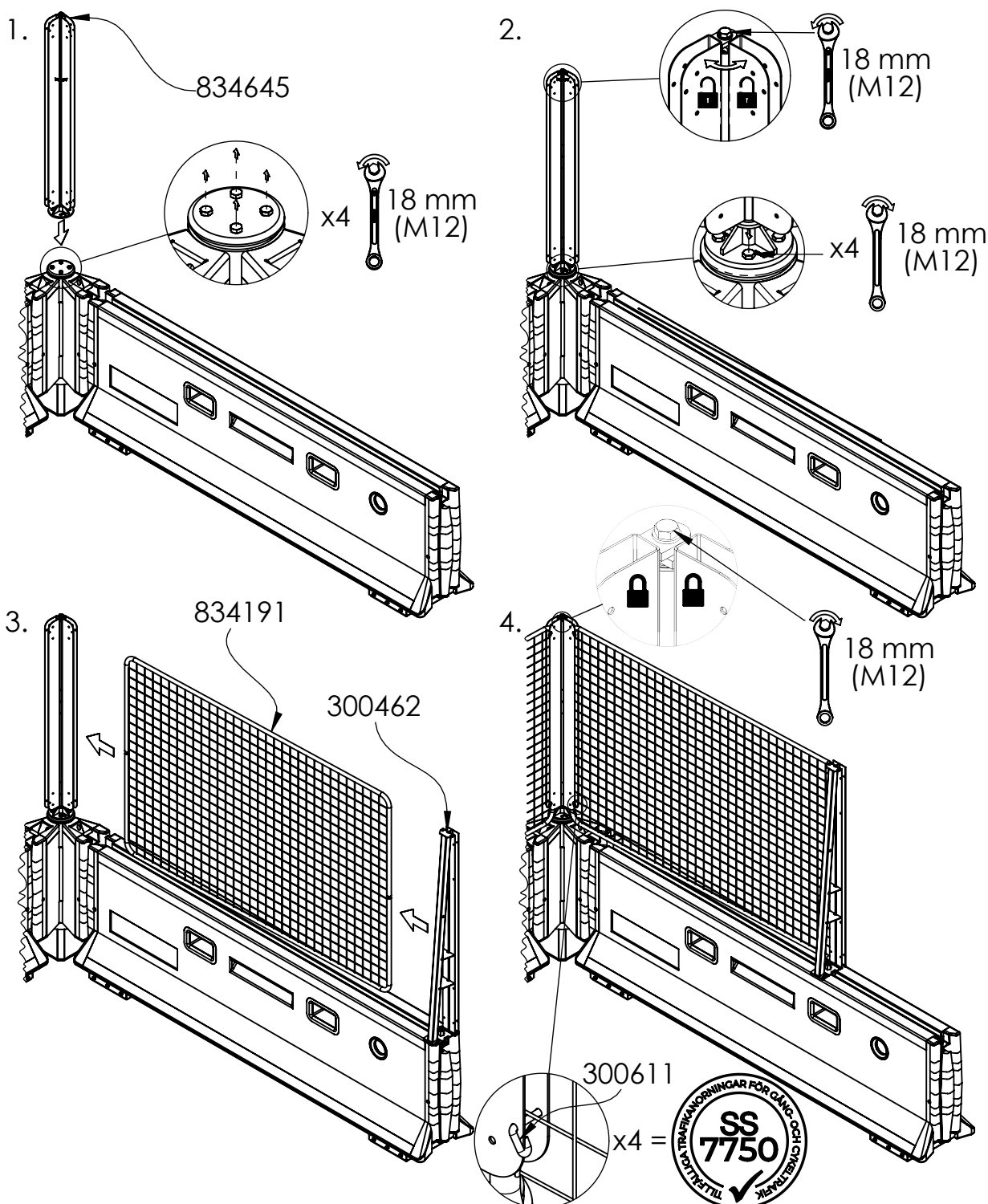

Montage

Skarvning

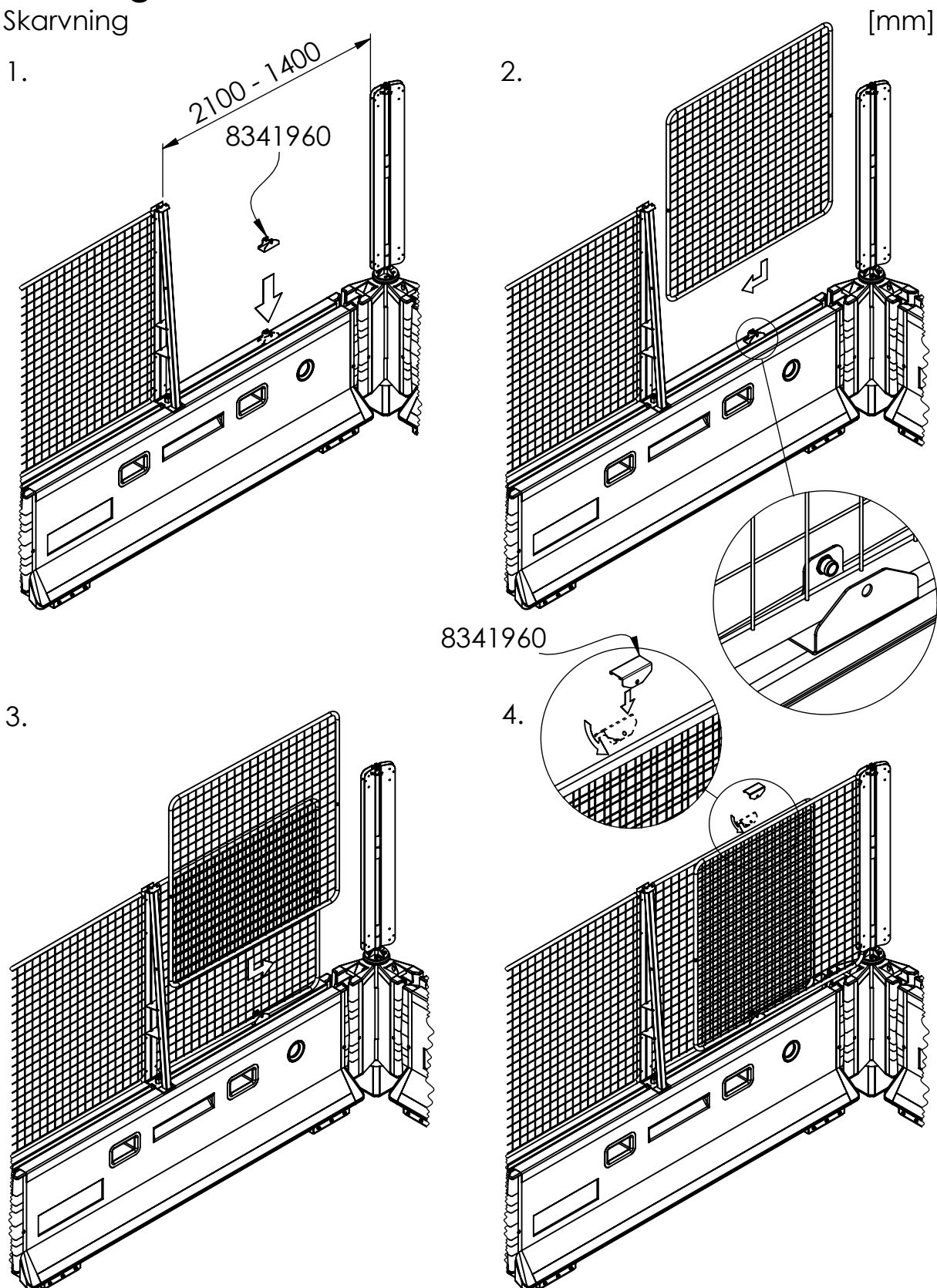

Montage

Skarvning

[mm]

5.

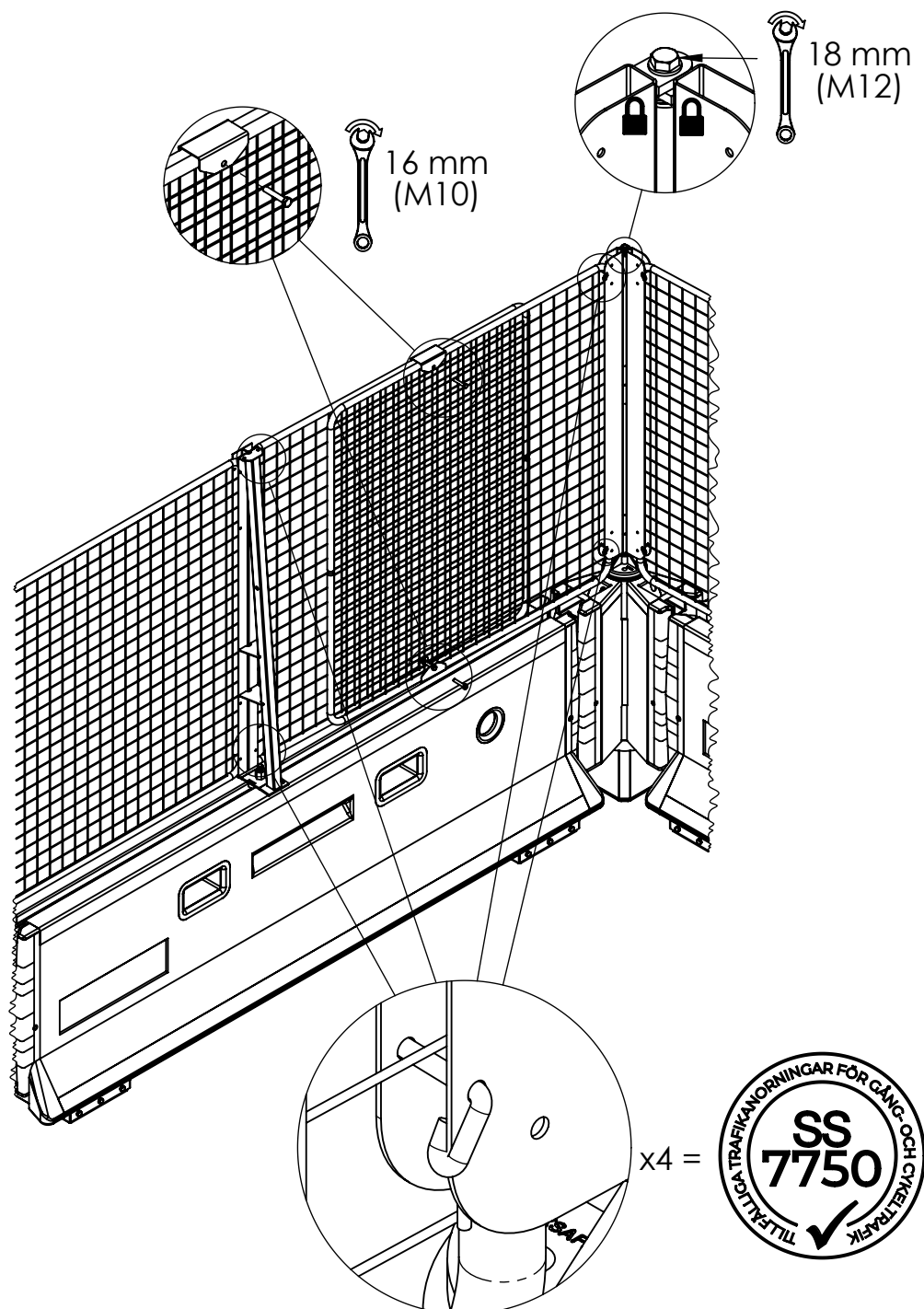

Montage



Om insynsskydd önskas kan GC-Räcket ersättas med 22-25 mm träspont. Var medveten om att en solid vägg ger ett stort vindfång och att uppställningen riskerar att tippa vid hård vind.

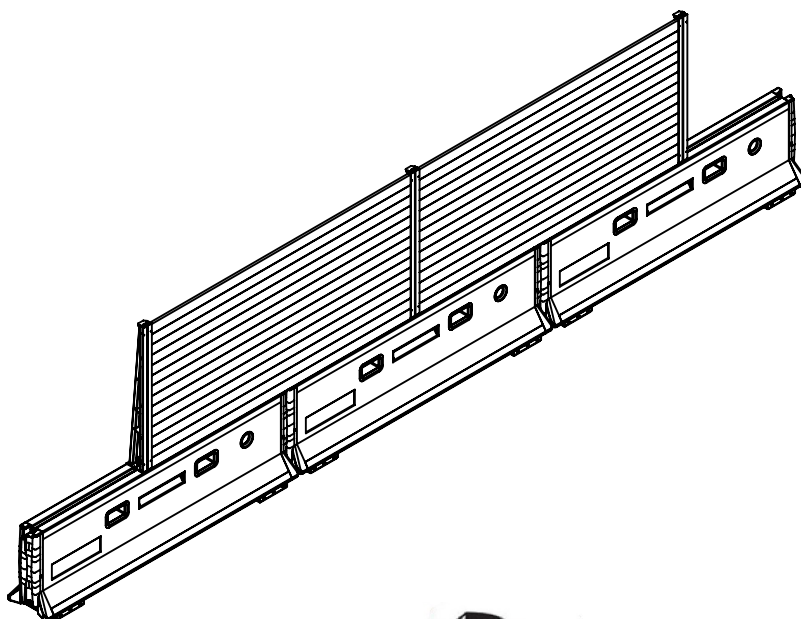

Vindhastighet vid
tippning

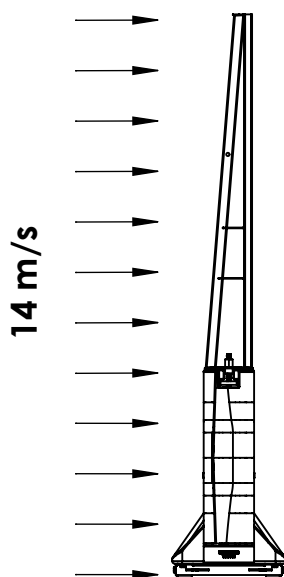















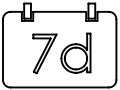

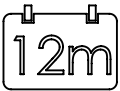
GENERELLT

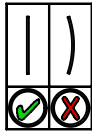
- Läs alltid igenom tillverkarens anvisningar för att säkerställa att produkten används på ett korrekt och säkert sätt.
- Vid oklarheter, kontakta tillverkaren eller aktuellt säljställe.
- Blanda aldrig produkter av olika fabrikat med varandra.
- Respektera alltid specificerade belastningsbegränsningar.

FÖRVARING

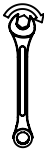
- Förvara i möjligaste mån produkterna i icke-korrosiv miljö.
- Tänk på att förvara produkterna på enligt tillverkaren avsett vis exempelvis vid stapling för att minimera risken för skador i samband med vältnig eller liknande.

 Teknisk information	 Vikt	 Nm Momentdra skruvförband
 Inspektera	 Återvinning	 Lossa skruvförband
 Inspektionsintervall i dagar	 Korrekt	 Max tillåten vindhastighet
 Inspektionsintervall i månader	 Inkorrekt	 Kraft
 Kontrollera rakhet	 Se upp!	 Moment
 Kontrollera sprickbildning	 Drag åt skruvförband	 "Trä i"